

REVISIONS

SYM	DESCRIPTION	DATE	APPROVAL
-----	-------------	------	----------

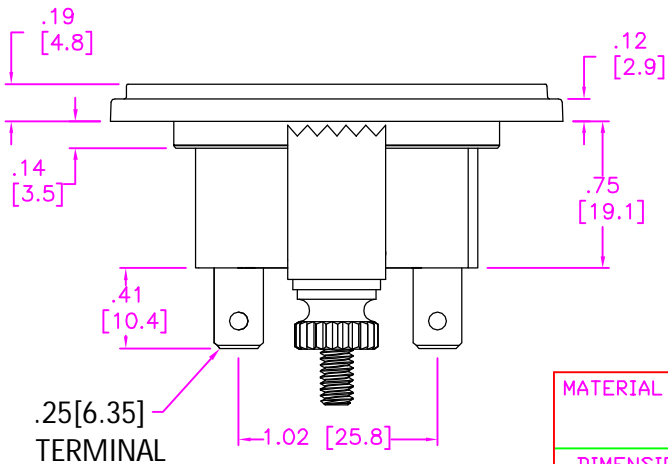
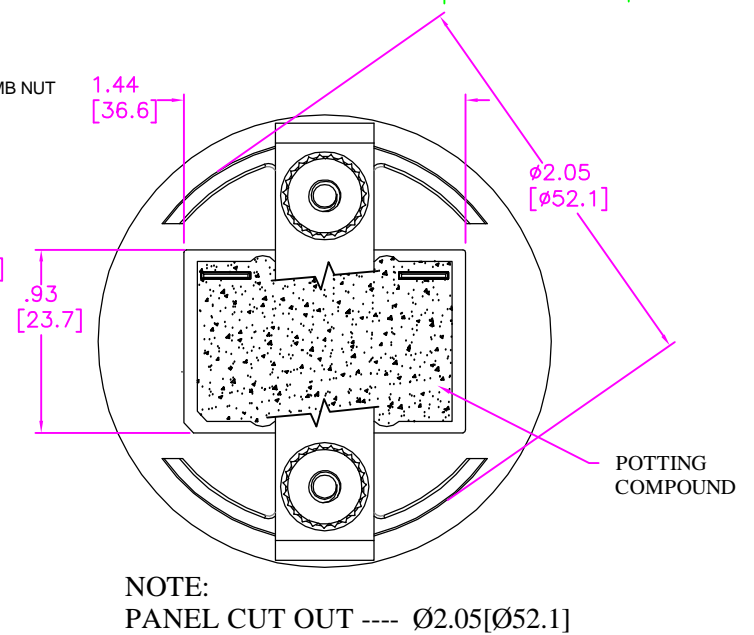
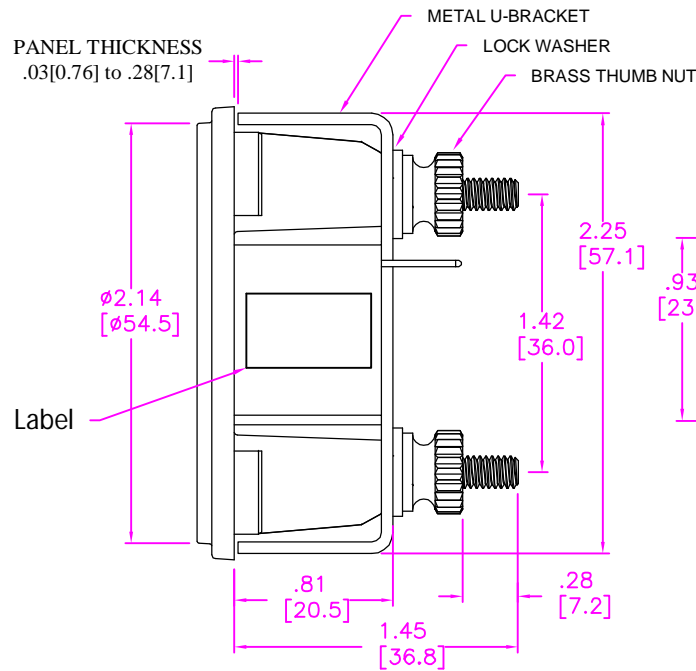
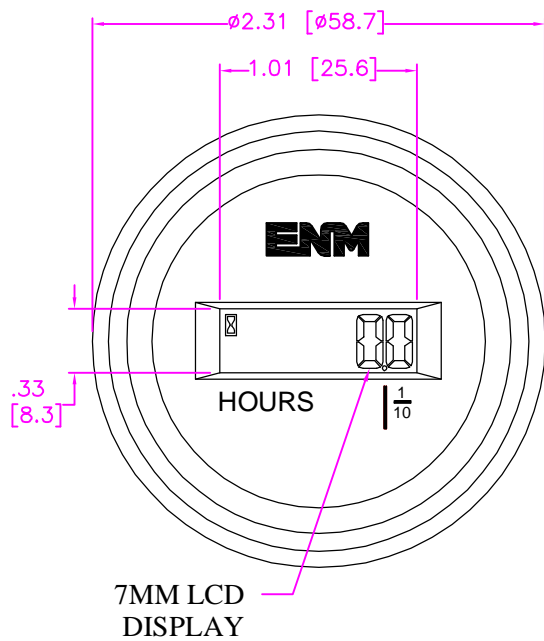

SPECIFICATION

- | | |
|---------------------------|-----------------------------|
| 1) DISPLAY | 99999.9 WITH RUNNING ICON |
| 2) DIGIT HEIGHT | 7MM |
| 3) RESOLUTION | 0.1 HOURS |
| 4) DATA STORAGE | EEPROM MEMORY |
| 5) INPUT DEVICE | 2 TERMINAL FOR POWER |
| | POLARITY INSENSITIVE |
| 6) OPERATION VOLTAGE | 115V TO 275V DC/ACV 50/60HZ |
| 7) OPERATION TEMPERATURE: | -40°C TO +85°C |
| 8) STORAGE TEMPERATURE: | -40°C TO +85°C |
| 9) HUMIDITY | 95 %RH |
| 10) TOTALLY SEALED UNIT: | POTTING METHOD (IP67) |

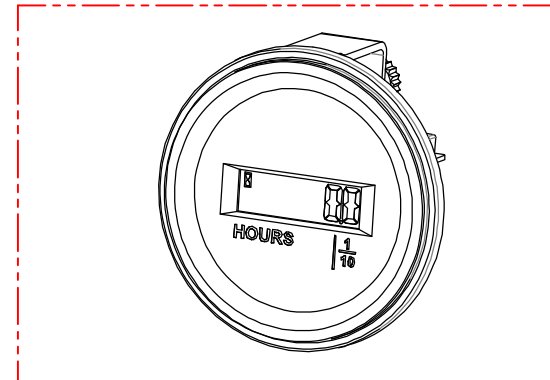

MATERIAL			FINISH			HEAT TREAT		
DIMENSIONAL TOLERANCES UNLESS OTHERWISE SPECIFIED			TITLE			WEIGHT		
FRAC.	DEC.	ANG.	6 DIGIT LCD HOUR METER METER WITH U-BRACKET FOR 2.05[52.1] DIAMETER CUTOUT			<h1>ENM</h1> Chicago, Illinois		
$\pm 1/64$.XXX $\pm .005$	$\pm 30^\circ$						
	.XX $\pm .01$							
SCALE	NO. REQ.D	DRAWN	J.G.	DATE	8/19/16	SIZE	DRAWING NUMBER	ISSUE
1.1		CHECKED		DATE		A	S-T44H69A	1
NEXT ASSY.		APPROVED		DATE				

THIS PRINT IS THE PROPERTY OF ENM COMPANY AND IS LOANED SUBJECT TO RETURN UPON DEMAND, TITLE TO SAME IS NEVER SOLD OR OF DESIGN OR INVENTION ARE RESERVED. PRINT IS NOT NECESSARILY TO SCALE.